

# Turbines and Fish: The Status of Fish-Friendly Hydropower Turbines

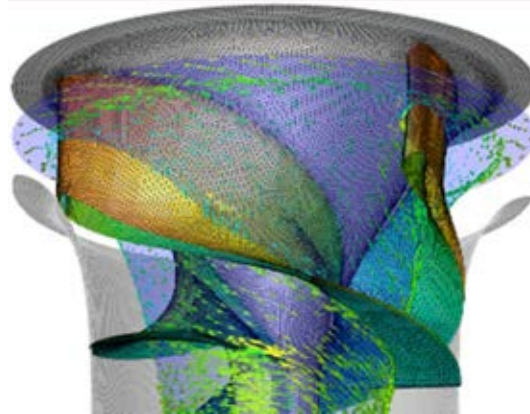
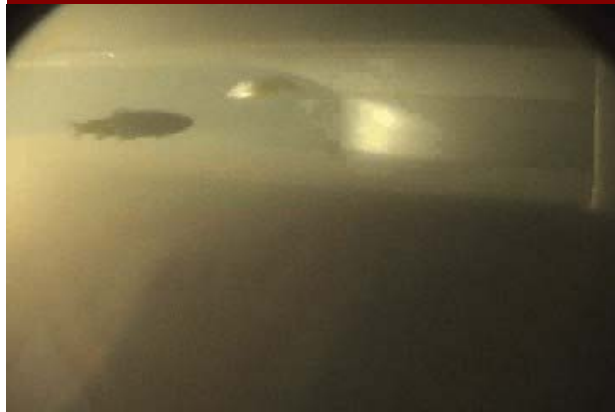

**Steve Amaral**

**ALDEN**

Solving flow problems since 1894

# Turbines and Fish: The Status of Fish-friendly Hydropower Turbines

## Presentation Outline

---

- Injury Mechanisms
- Estimating Turbine Survival
  - Theoretical Models
  - Field Methods
- Fish-friendly Turbine Designs
- Summary

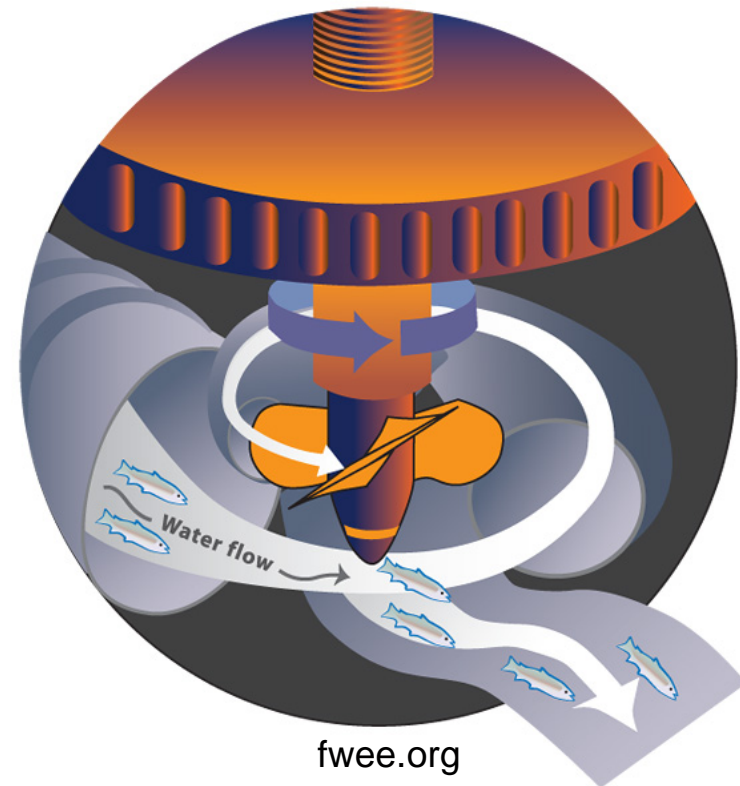

# Direct, Indirect, and Delayed Mortality Resulting from Turbine Passage

---

- **Direct Mortality** – Lethal injuries suffered during turbine passage.
- **Indirect Mortality** – Sub-lethal injuries suffered during turbine passage that lead to mortality from increased stress, predation, or disease.
- **Delayed Mortality** – Occurs in lower river, estuary, or marine environment and can be attributed to passage through one or more dams.



# Injury Mechanisms

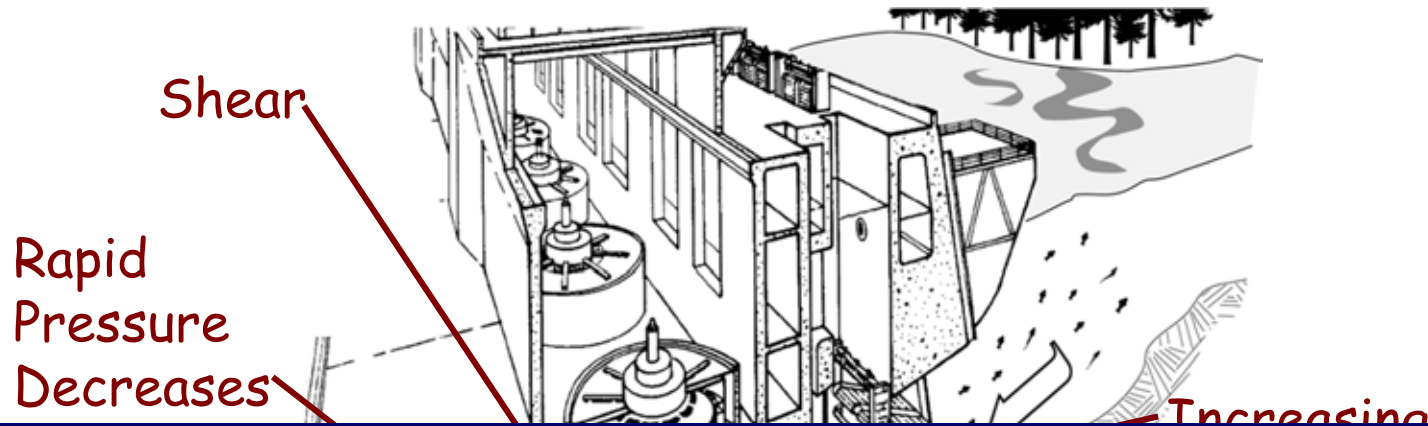

Depending on fish length and turbine design/operation, about **5 to 30%** of fish passing through hydro turbines are killed.

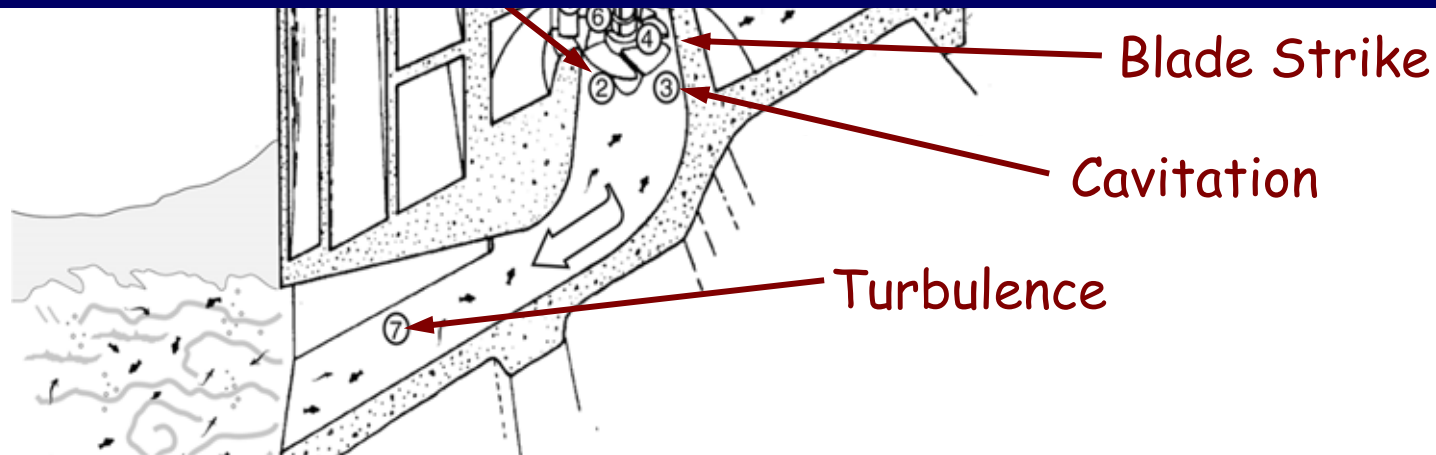

Cada et al. 1997

# Injury Mechanisms

## *Pressure*

***Pressure-related injury potential is dependent on:***

- Minimum absolute pressure
- How rapidly pressure changes occur
- How quickly fish can adjust to changes
- Acclimation pressure (ratio of pressure change)

***Recommended Minimum Pressure:***

- 7.5 to 15 psi (50 to 100 kPa), depending on species

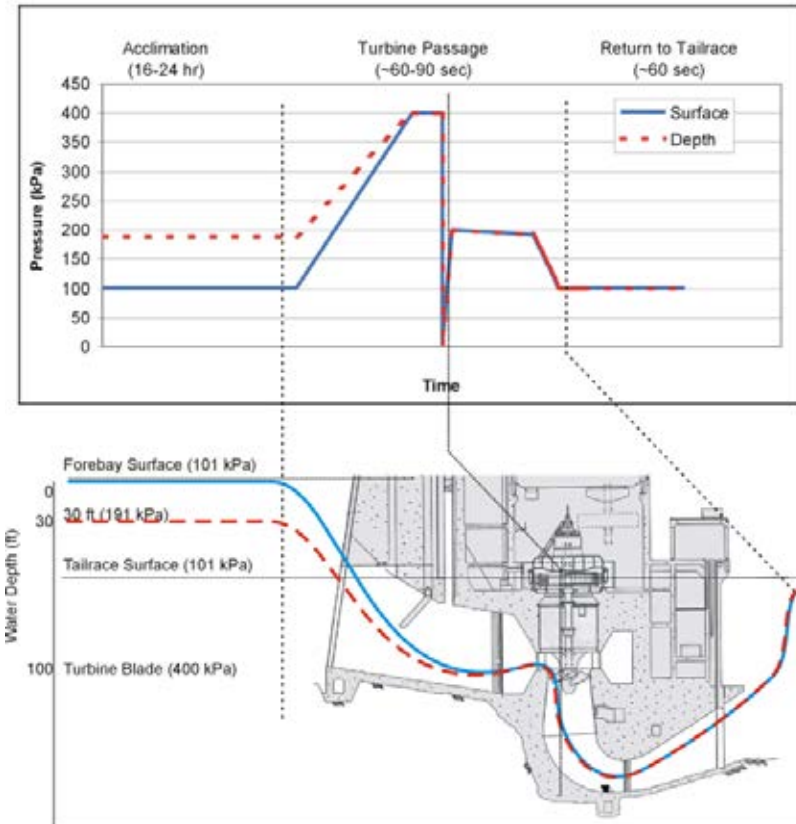

Abernethy et al. (2001)

# Injury Mechanisms

## *Pressure*

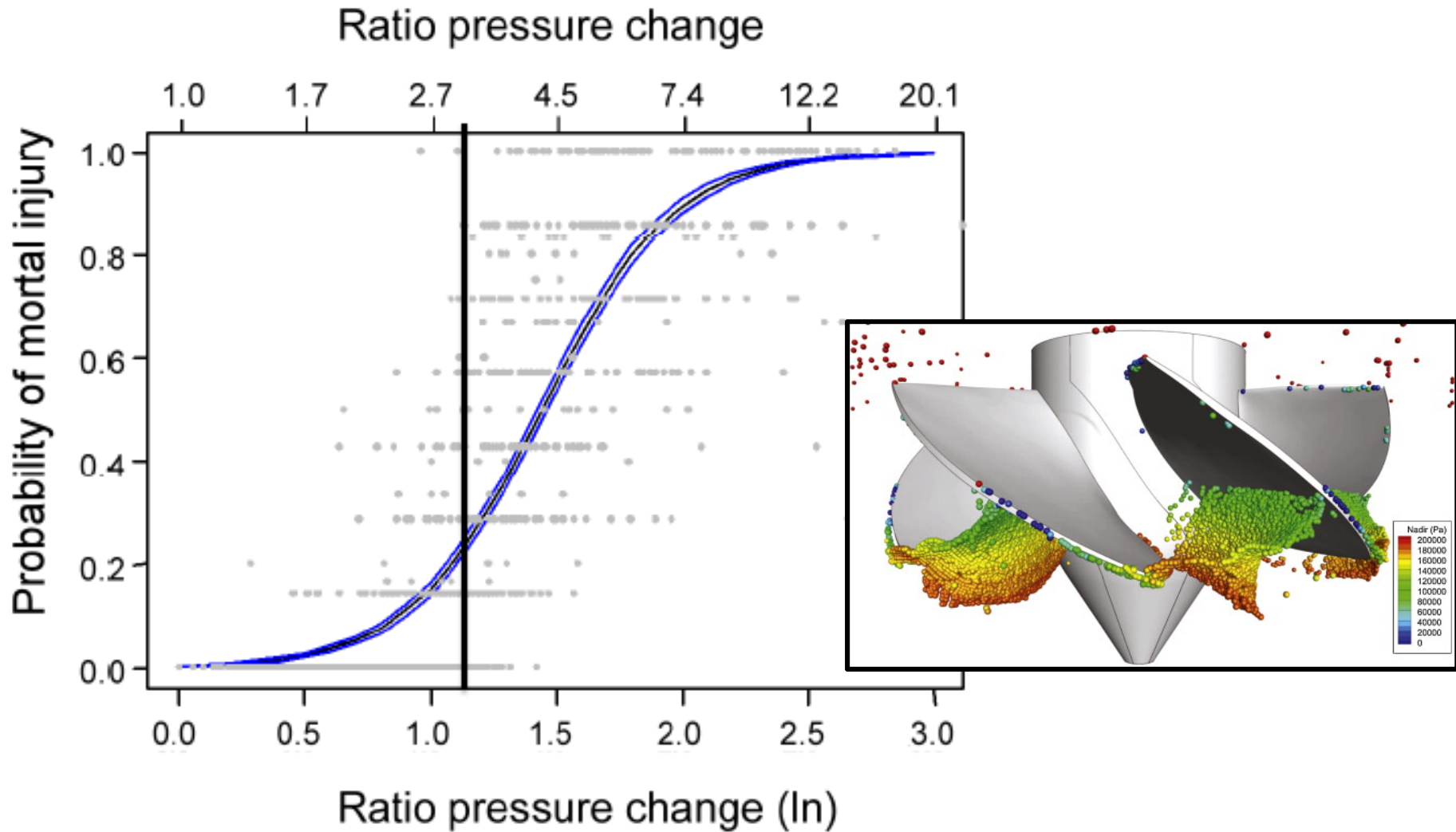

# Injury Mechanisms

## *Mechanical*

---

***Contact with structural components leading to injury and mortality, including:***

- Collisions between fish and moving turbine blades and fixed structures, such as stay vanes, wicket gates, and other types of guides or flow straighteners.
- Grinding or pinching from passage through narrow openings or gaps between stationary and/or moving components (e.g., blade tips and outer ring)
- Abrasion from contact with a stationary or moving surface.

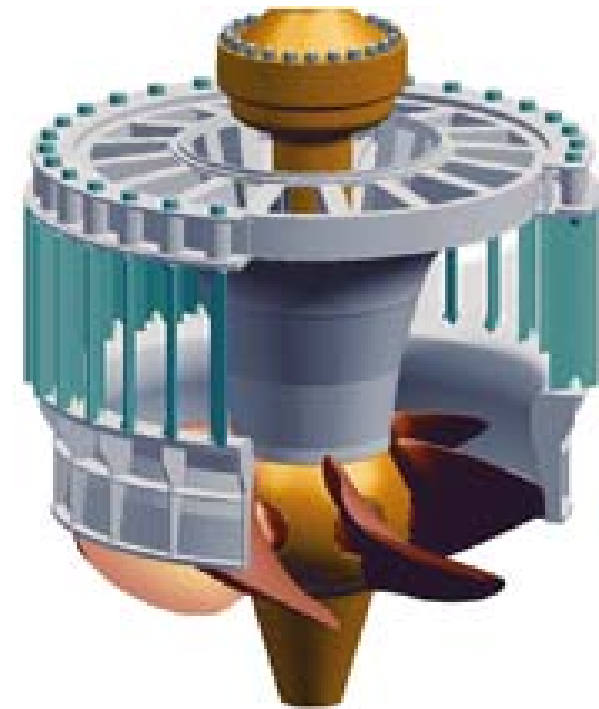

Voith.com

# Injury Mechanisms

## *Blade Strike*

- Primary mechanism of fish injury and mortality at many hydro projects.
- Strike probability depends on blade spacing, rotational speed, relative velocity of fish to blade, and fish length.
- Little difference in mortality rates among typical teleost (boney) fishes.
- Recent studies have demonstrated that blade strike survival can be greater than 90% at strike speeds up to 12.1 m/s depending on fish length and blade leading edge thickness.



# Injury Mechanisms

## *Blade Strike Mortality*

---

***Blade strike survival is affected by:***

- Blade shape
- Blade thickness
- Impact speed
- Fish length

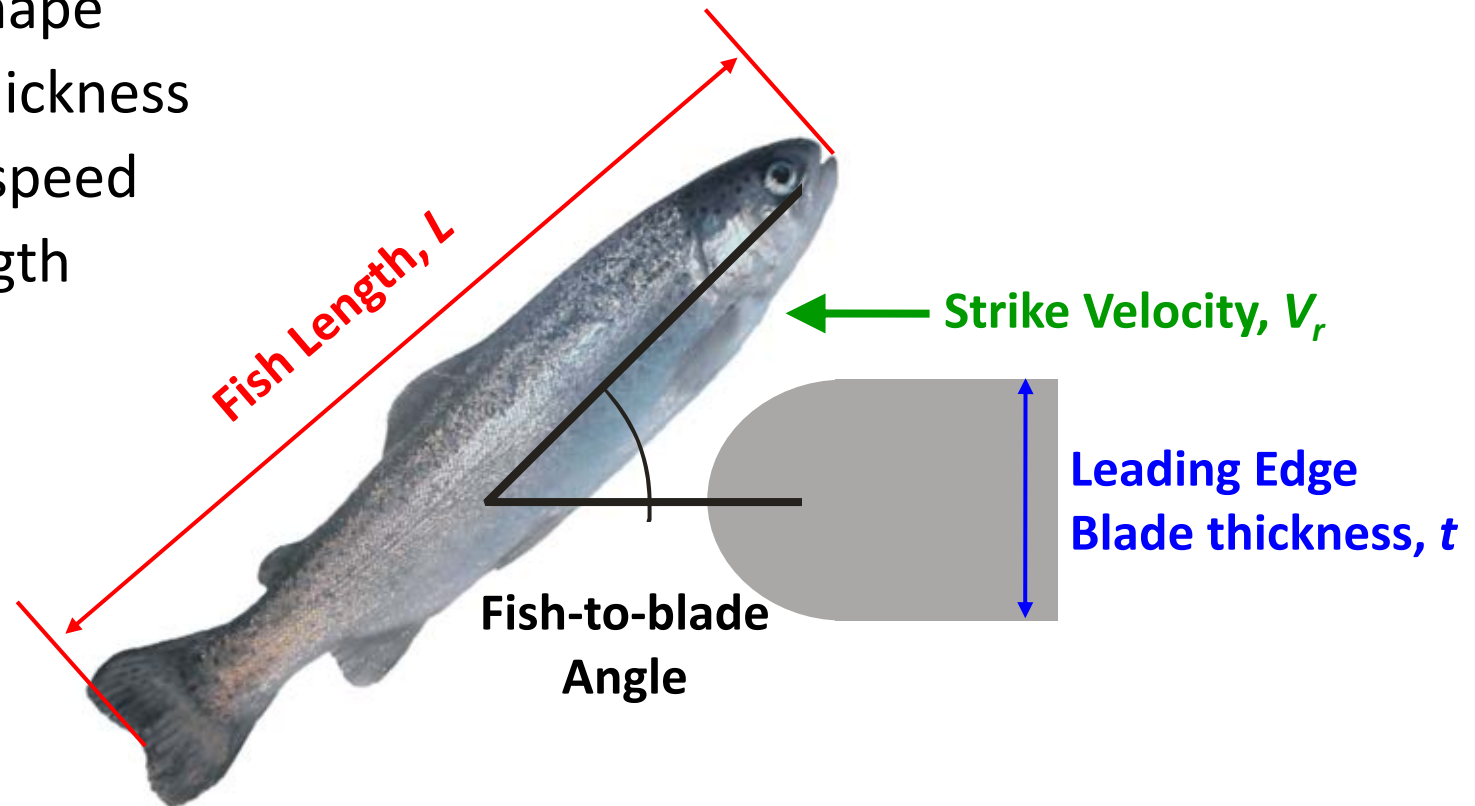

# Injury Mechanisms

## *EPRI Blade Strike Survival Data*

- Linear facility:  
55 ft L x 3 ft W x 3 ft H
- Accelerated blade to strike speed, then stopped it after impact with fish
- Recorded impact using high speed video system
- Examined fish for injury and survival for each set of test parameters
- Estimated immediate (1-hr) and total (1-hr + 96hr) survival

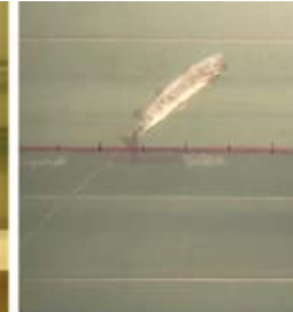
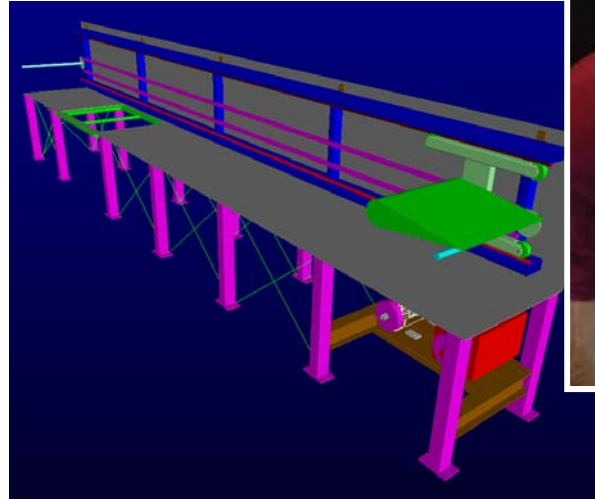

# Injury Mechanisms

## *EPRI Blade Strike Survival Data*

### *Rainbow Trout*

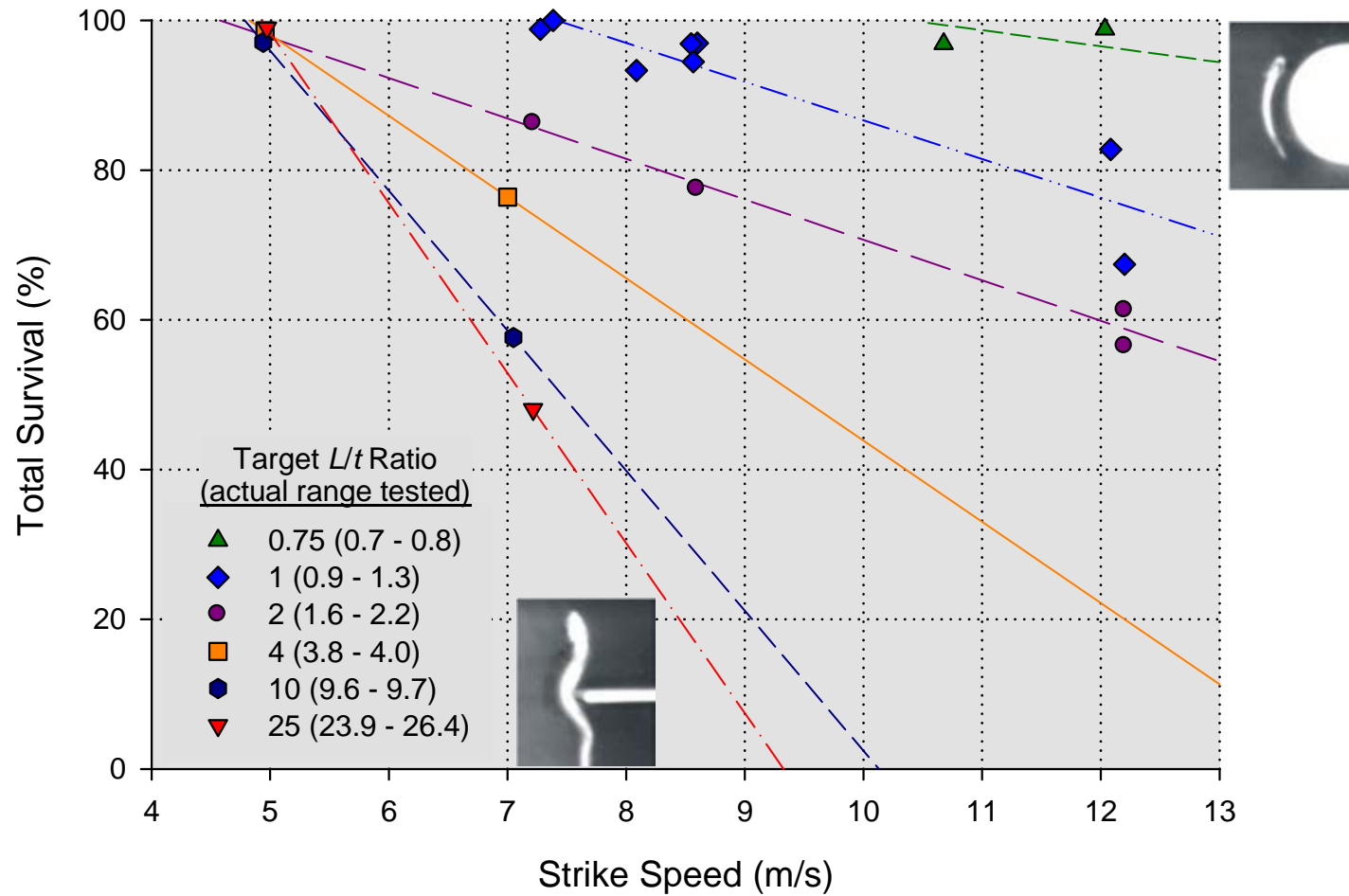

# Injury Mechanisms

## *EPRI Blade Strike Mortality Survival Data*

*White Sturgeon and Rainbow Trout  
Strike velocities: 10 to 12 m/s*

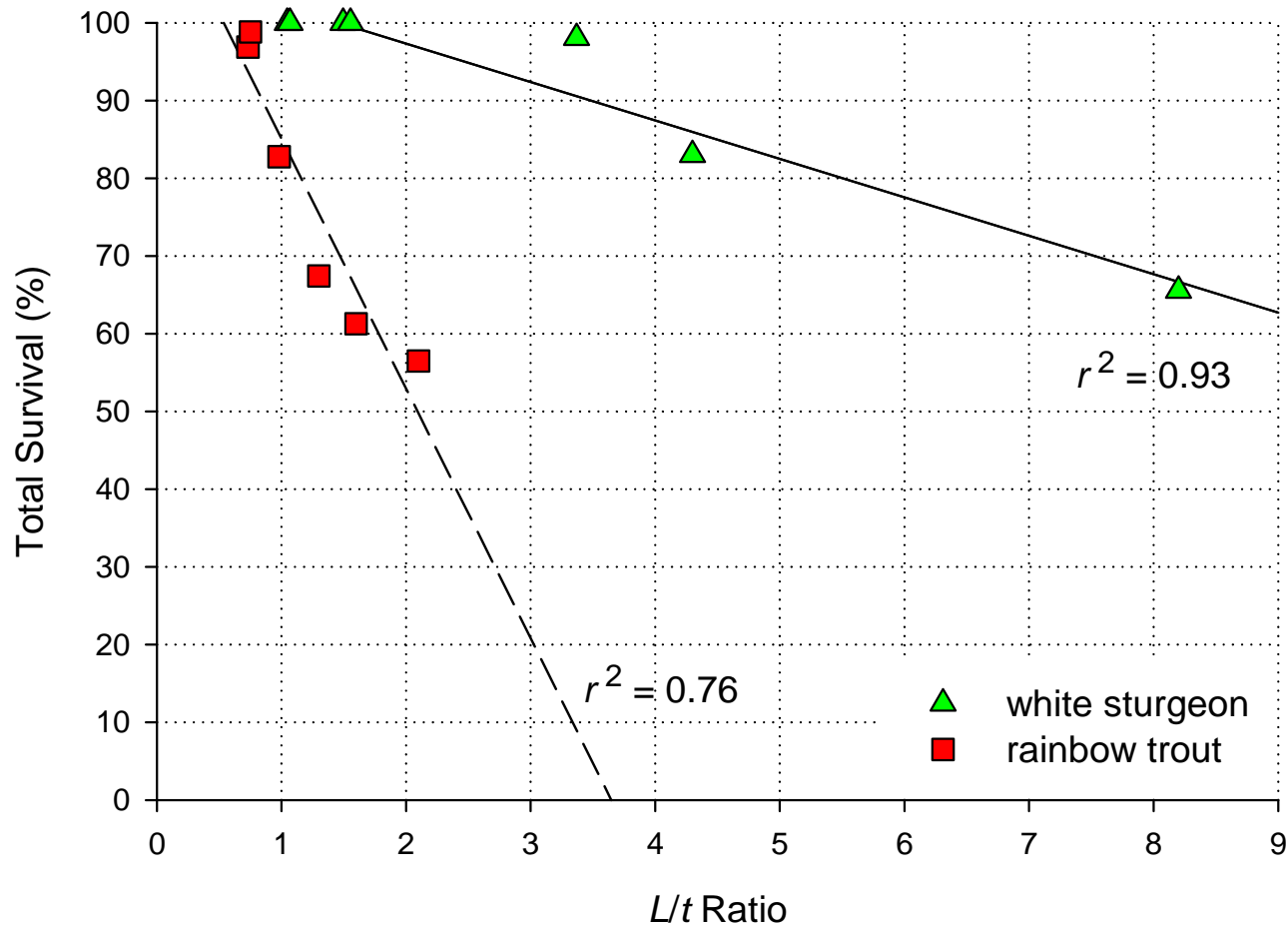

# Injury Mechanisms

## *EPRI Blade Strike Study - Video*

---

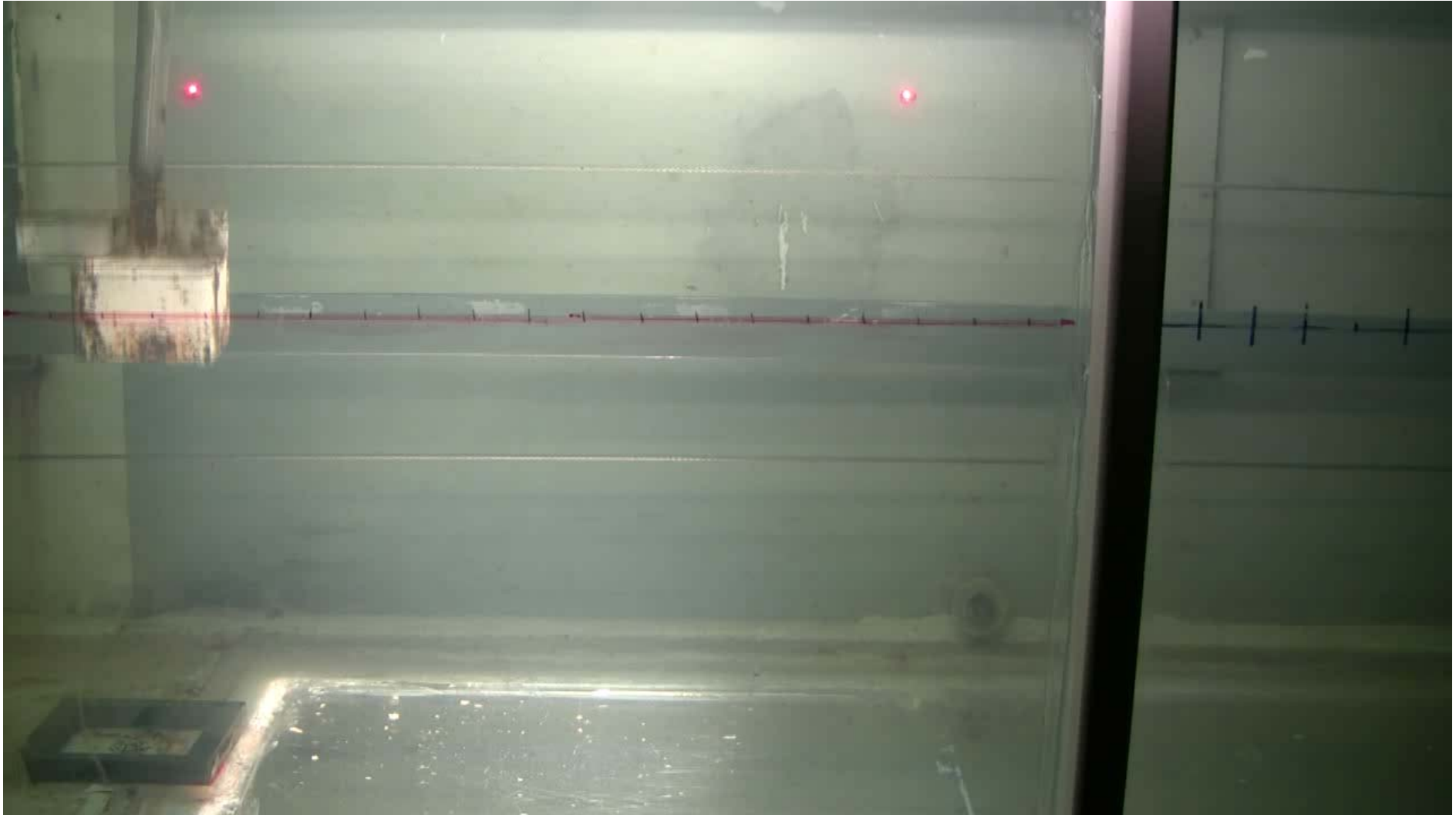

# Injury Mechanisms

## *EPRI Blade Strike Study - Video*

---

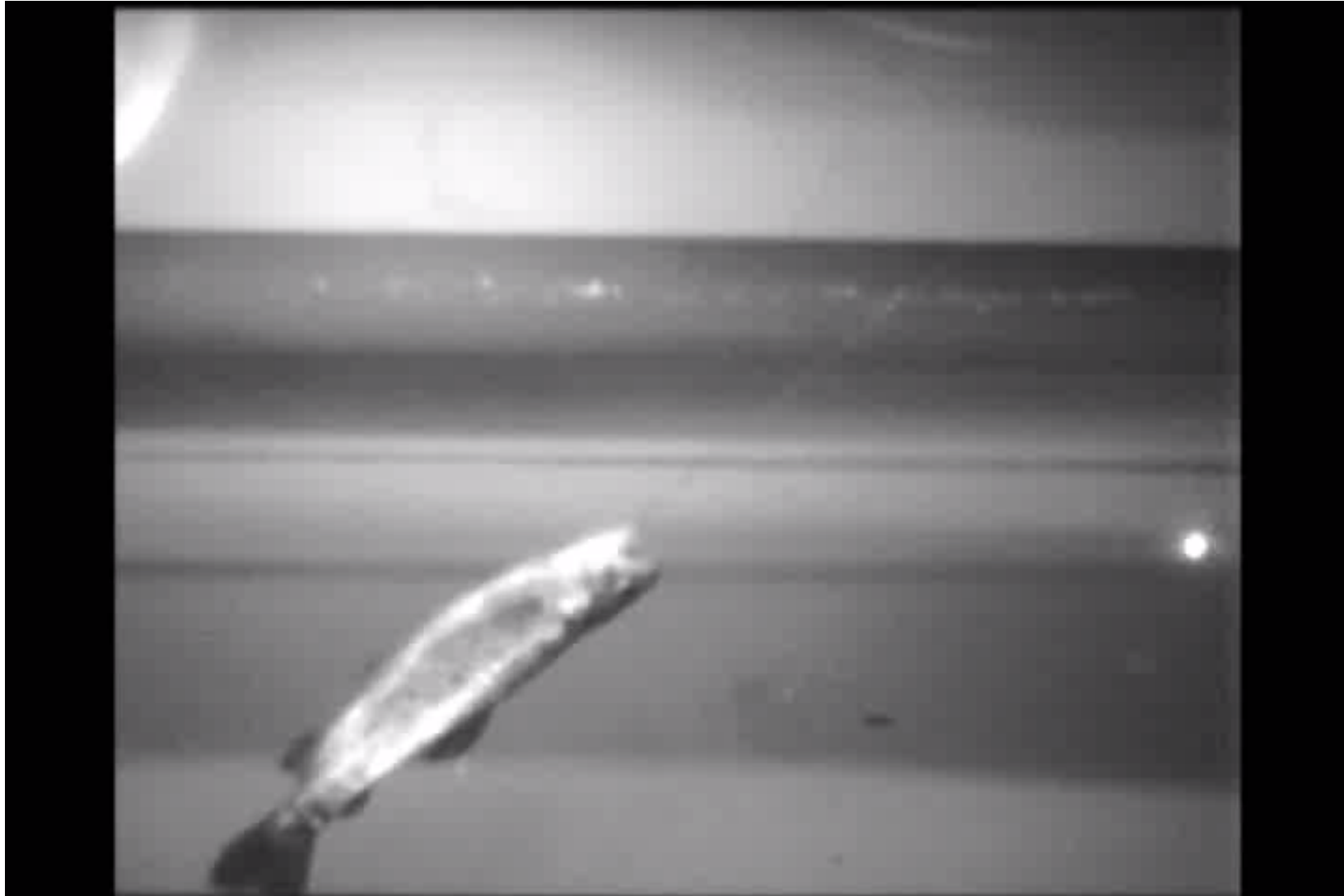

# Estimating Turbine Passage Survival

## *Blade Strike Probability and Mortality*

$$\text{Strike Probability} = n(L \sin \alpha)N / (60V_{ax})$$

$n$  = rpm

$L$  = Fish Length

$\alpha$  = Inflow Angle;

$N$  = Number of Blades

$V_{ax}$  = Axial/Radial Velocity

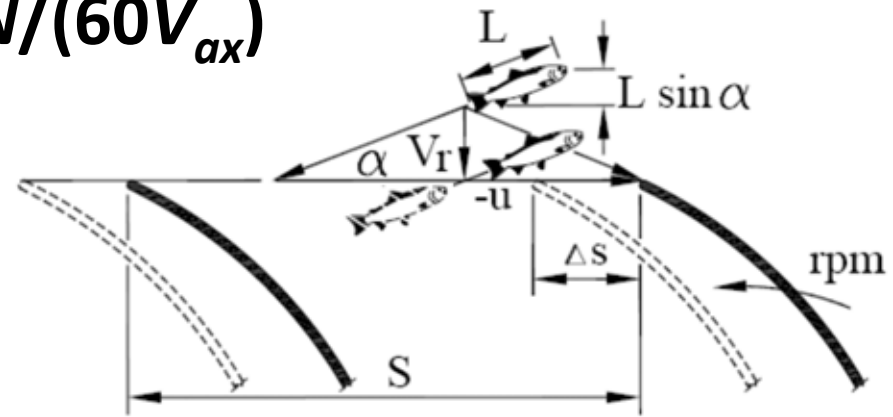

$$\text{Turbine Survival} = K n(L \sin \alpha)N / (60V_r)$$

where  $K$  is % mortality from strike

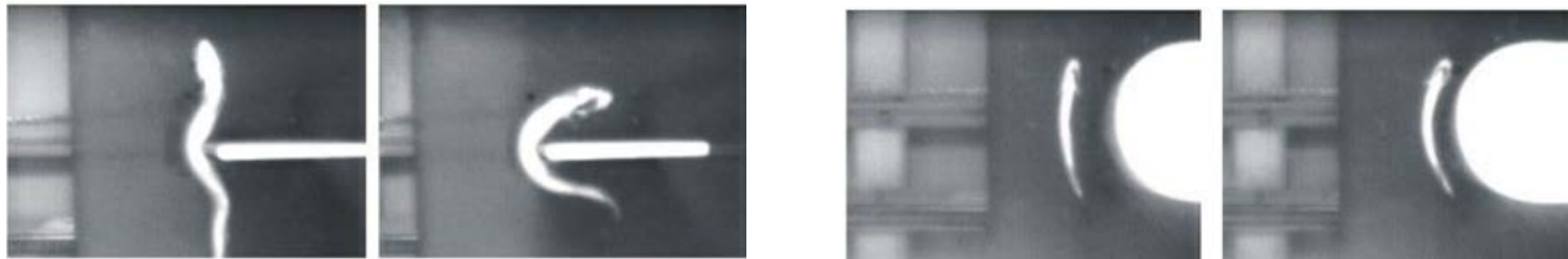

(EPRI 2008, 2011)

# Field Measurement Techniques

- Netting
- Telemetry techniques
- Balloon tags



Deng et al. (2012)



Normandeau Associates (2009)



# Field Measurement Techniques

## *Balloon Tagging*

---

- Hi-Z Turbin Tag developed by Normandeau Associates
- Direct turbine survival estimates
- High recovery rates
- High control survival
- Ability to examine fish for internal and external injuries
- High statistical precision
- Potential barotrauma bias



Normandeau Associates (2010)

# Fish-Friendly Turbine Designs

## *What Makes a Turbine Fish-friendly?*

---

- Small number of blades (large spacing between blades)
- Large diameter
- Low rotational speeds
- Low head
- High minimum pressure
- Optimal hydraulics
- Efficient operation

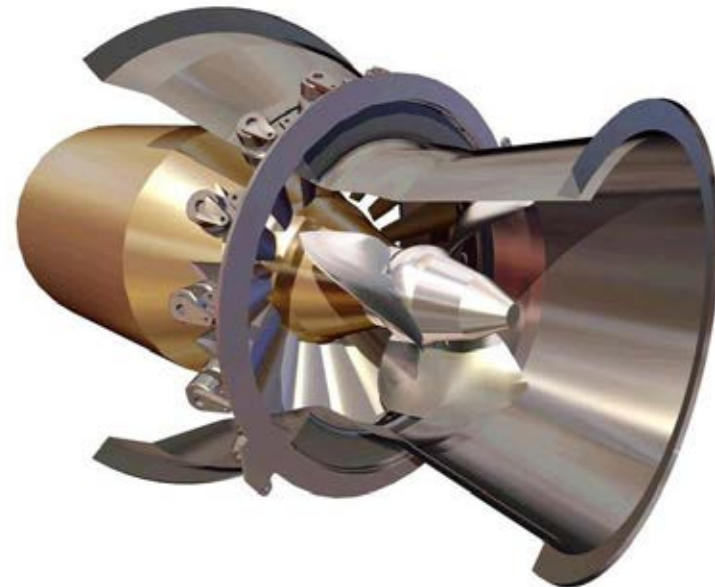

# Fish-Friendly Turbine Designs

## *Minimum Gap Runner (MGR)*

### Standard Kaplan

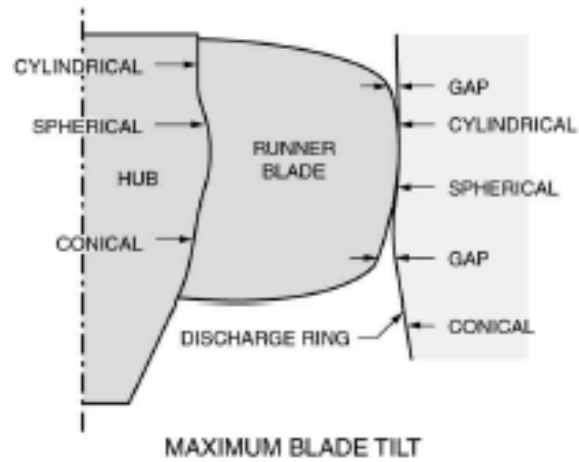

### Minimum Gap Runner

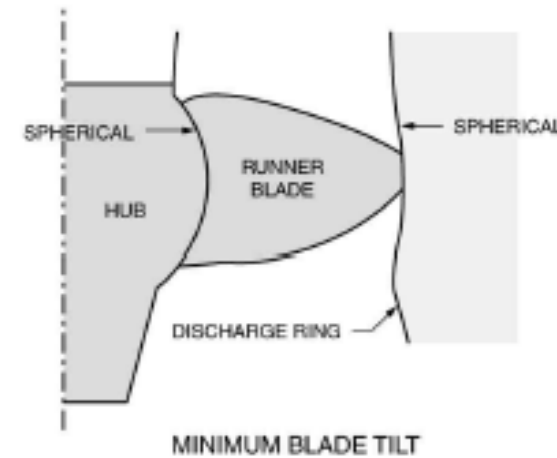
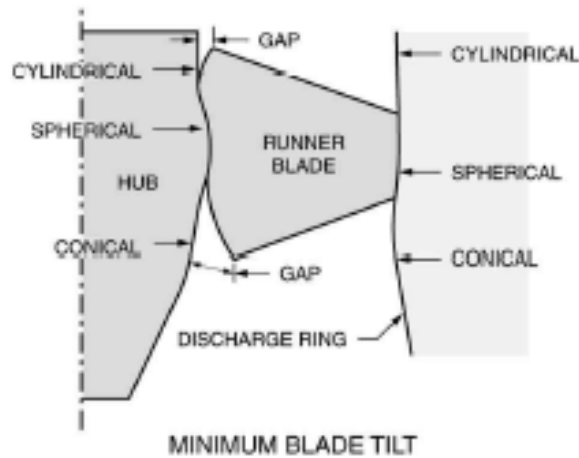
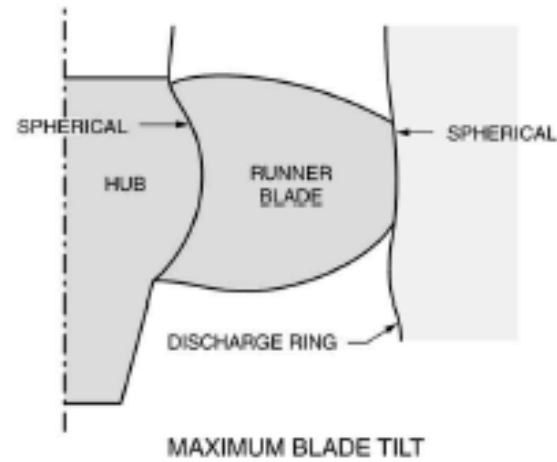

Source: Voith Hydro

# Fish-Friendly Turbine Designs

## *Minimum Gap Runner (MGR)*

---



**Voith MGR**

### ***Voith MGR Field Tests***

- Bonneville: 97% survival; 3% greater than existing Kaplan units.
- Wanapum Dam: 97.0% average survival (existing unit: 97.5% average survival).

# Fish-Friendly Turbine Designs

## *Alden Turbine*

- Three helical blades
- Few/long gates
- Smooth downturn
- Shroud attached to blades
- No gaps
- Favorable hydraulics
- High minimum pressure

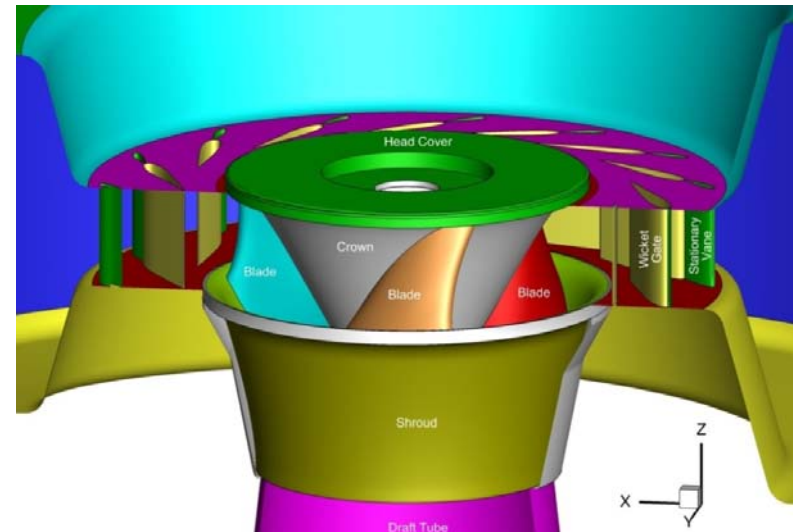

### *Prototype Design*

- Head: 6 to 35 m
- Flow: 15 to 80 m<sup>3</sup>/s

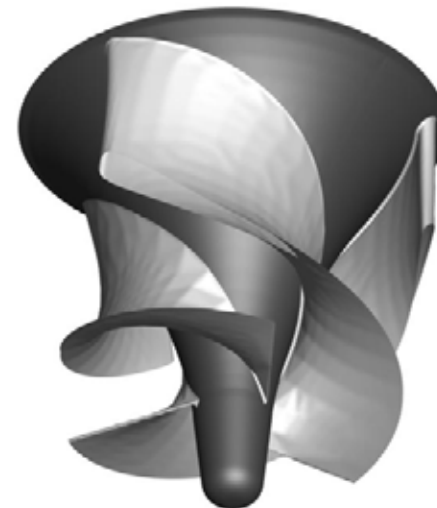

# Fish-Friendly Turbine Designs

## *Alden Turbine – Biological Testing (Pilot-scale)*

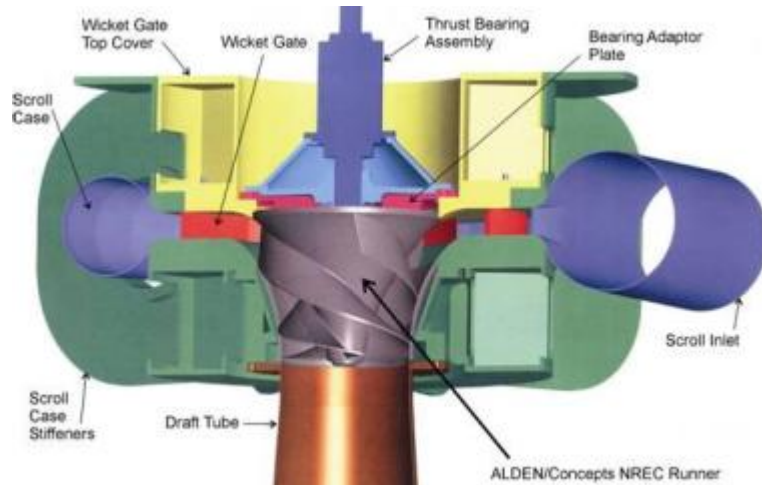

- 1.2 m diameter turbine (1:3 scale)
- 12 and 24 m head
- 240 and 345 rpm
- With and without Wicket gates
- BEP and off-BEP gate settings
- 6 species, multiple size groups

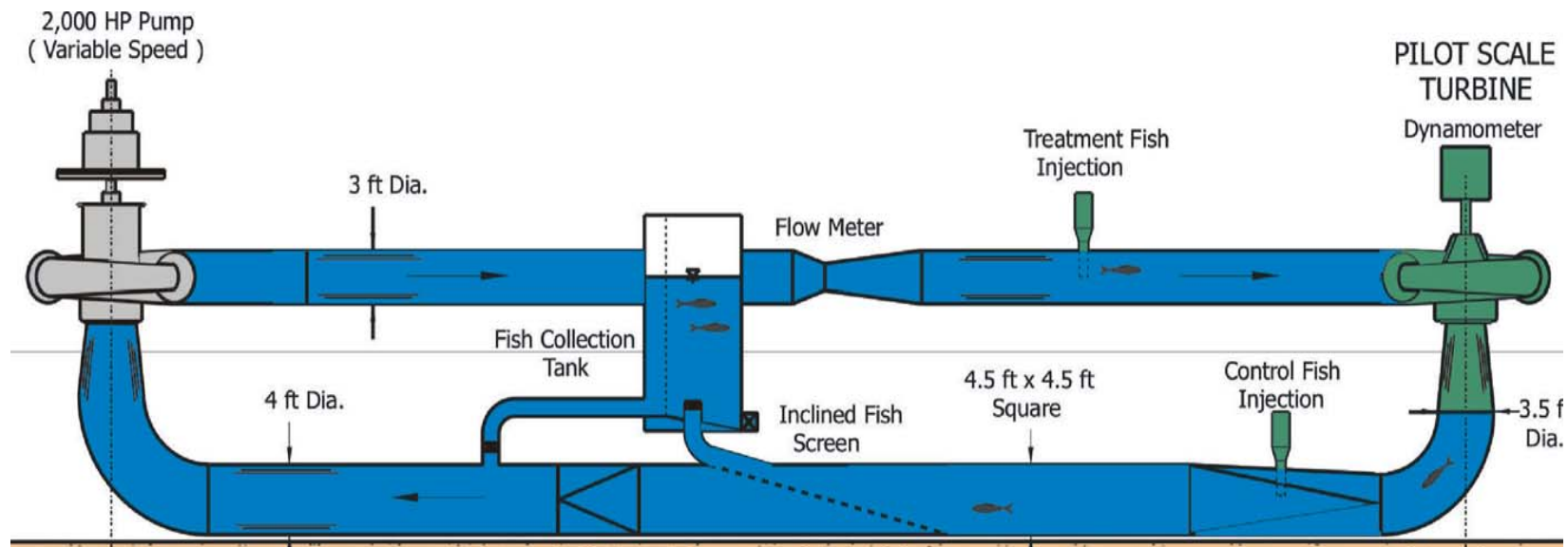

# Fish-Friendly Turbine Designs

## *Alden Turbine – Biological Testing (Pilot-scale)*

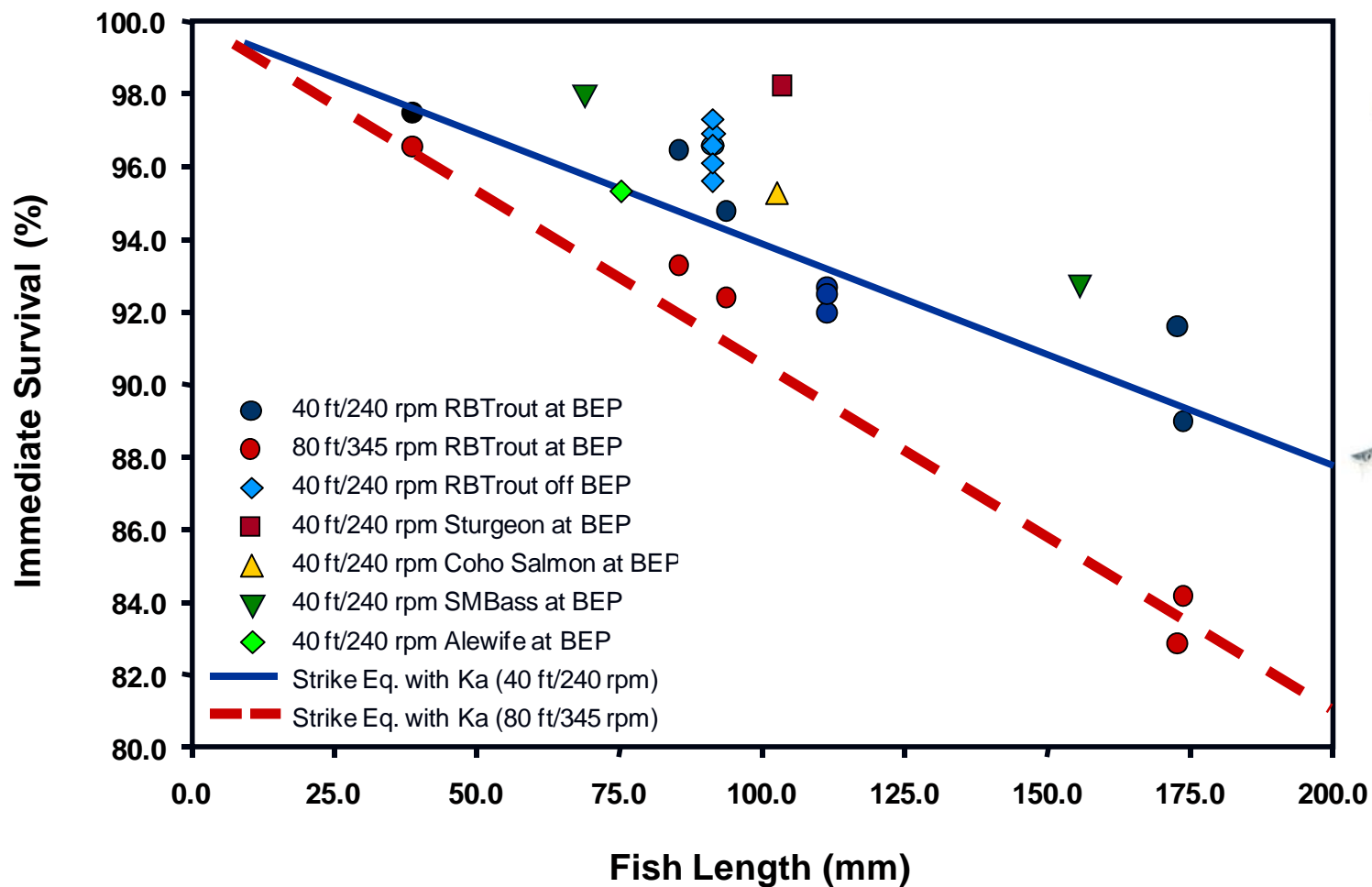

# Fish-Friendly Turbine Designs

## *Alden Turbine – Biological Testing (Pilot-scale)*

---

***RAINBOW TROUT (170 MM) TESTED AT 40 FT HEAD (245 RPM) WITHOUT WICKET GATES***



**ALDEN**

Solving flow problems since 1894

# Fish-Friendly Turbine Designs

## *Alden Turbine*

### ***Full-Scale Survival Predictions (4 m diameter, 110 rpm)***



Coho salmon



Rainbow trout



Smallmouth bass



Alewife

=< 200 mm (8 inches)

**98 – 100%**



American eel



White sturgeon

=< 600-1,000 mm (24-40 in)

**99 – 100%**

# Fish-Friendly Turbine Designs

## *Alden Turbine*

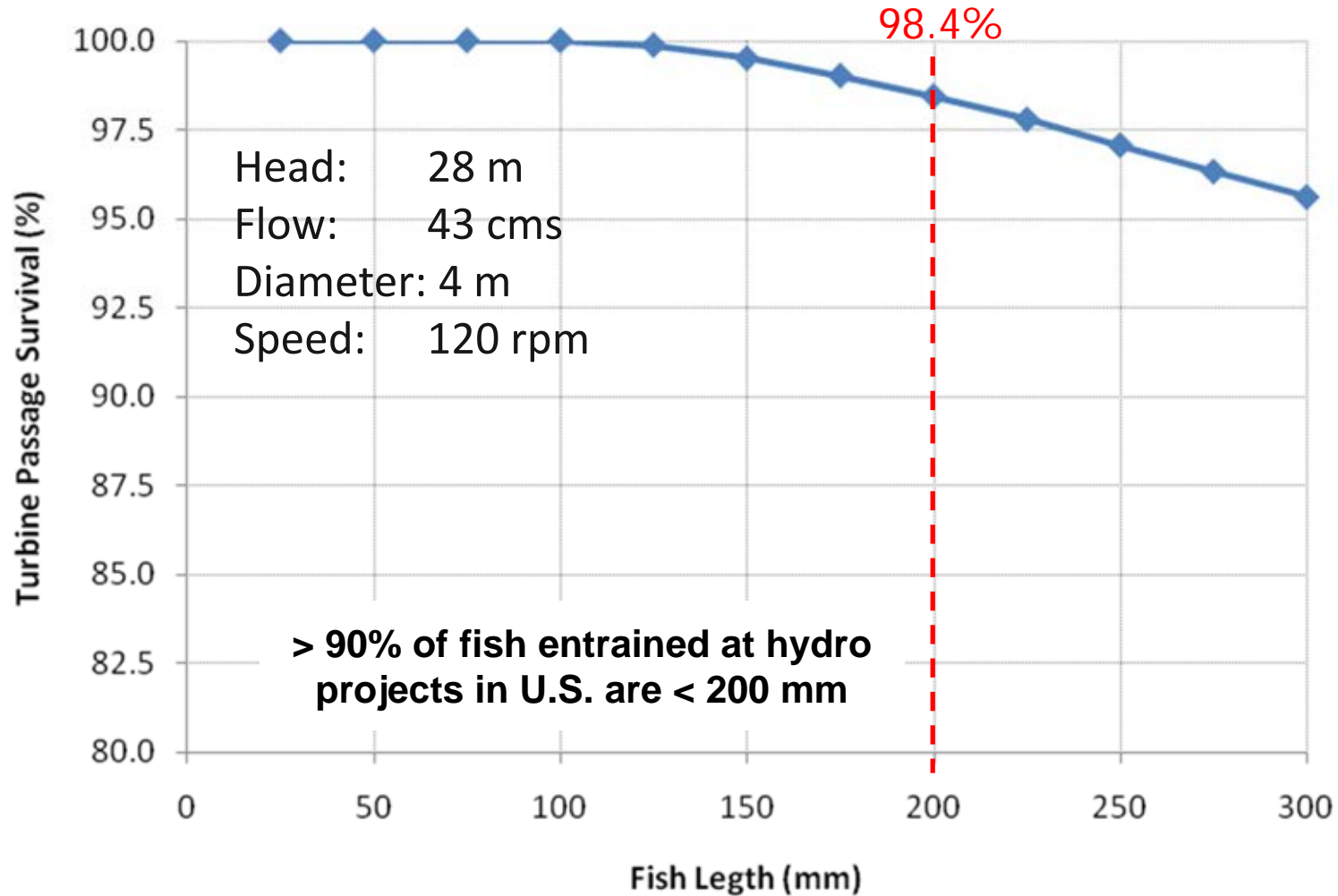

# Fish-Friendly Turbine Designs

## *Low Head Turbines*

**Archimedes Screw Turbines**  
< 10 m head



**MJ2 Technologies**  
**Very Low Head turbine (VLH)**  
< 6 m head



**Gault Green Energy**  
**Vaneless Turbine**  
< 6 m head

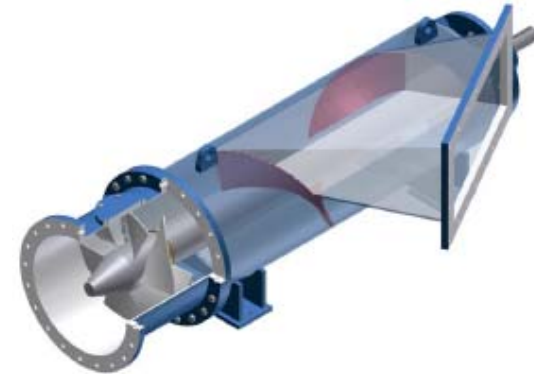

**Turbine Survival: 95 to 100% for salmonids and eels**

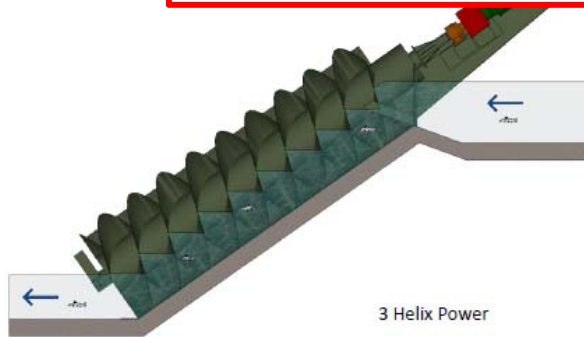

Leclerc (2008)



de Montmorency (2008)

# Fish-Friendly Turbine Designs

## *Low Head Turbines*

### *Pentair Fairbanks Nijhuis/FishFlow Innovations Fish-friendly Turbine*

- < 6 m head
- Three blades
- Variable speed
- 60 – 90 rpm for 4-m diameter unit
- 100% eel survival in pilot-scale tests

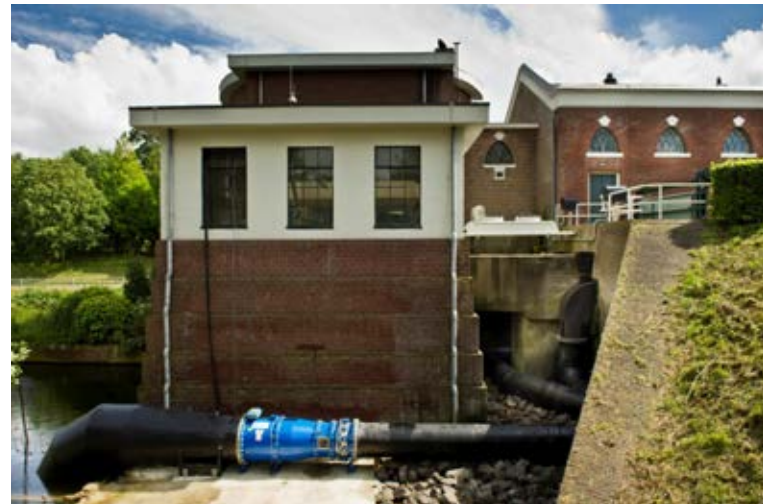
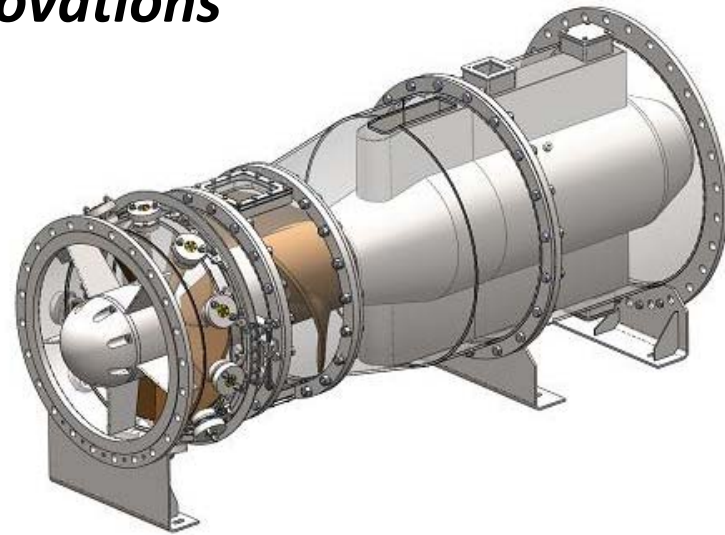

# Fish-Friendly Turbine Designs

## *New Turbine Design for Ice Harbor Dam*

---

***US Army Corp of Engineer is currently contracting with Voith Hydro to install fish friendly runners at Ice Harbor***

- Ice Harbor is most downstream dam on the Snake River.
- Significant focus at the project on improving survival of downstream migrating juvenile salmonids some of which are listed under the ESA.
- Collaborative design effort with COE, BPA, NMFS and Voith Hydro.
- Two adjustable and one fixed-blade will replace 3 Kaplan Units.
- Used pressure studies to develop design criteria of limiting areas below 12 psia while reducing strike, shear and turbulence



# Fish-Friendly Turbine Designs

## *New Turbine Design for Ice Harbor Dam*

- Iterative design and evaluation process includes baseline model testing, CFD development and analyses, performance model testing and observational model testing with Froude Scale physical model
- Runner and other water passageway modifications are in fabrication.
- Installation starting next year with biological testing in 2017 for the fixed and 2018 for the adjustable.

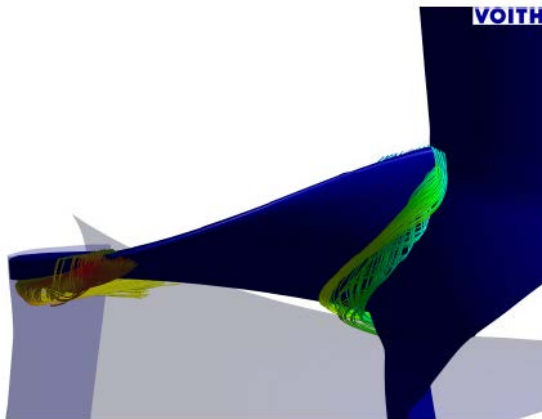
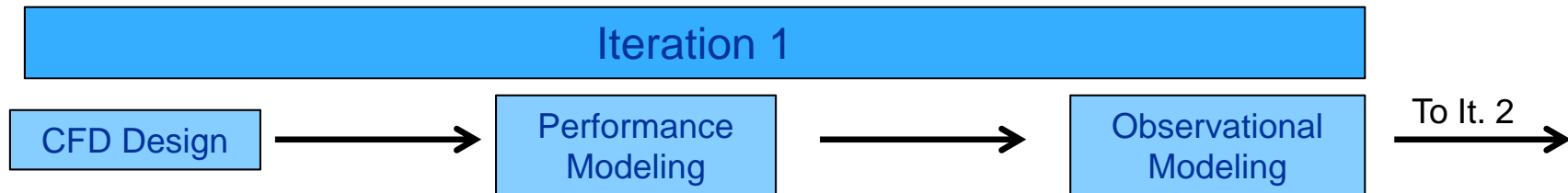

**ALDEN**  
Solving flow problems since 1894



# Summary

- Barotrauma and strike damage are often the primary injuries suffered by fish passing through turbines.
- Blade strike typically is the most prevalent injury mechanism at many low head projects (< 15 m).
- Theoretical strike probability and mortality models can be used to estimate turbine survival for most species entrained through Francis and propeller-type turbines.
- Telemetry techniques and balloon tagging are effective methods for estimating turbine survival in the field.
- The development of fish-friendlier turbines has seen significant advancements in recent years, which has led to a variety of designs that can be applied to a wide range of projects.

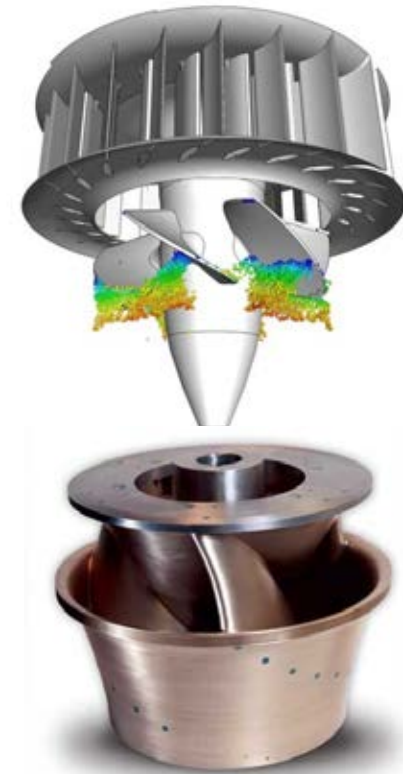
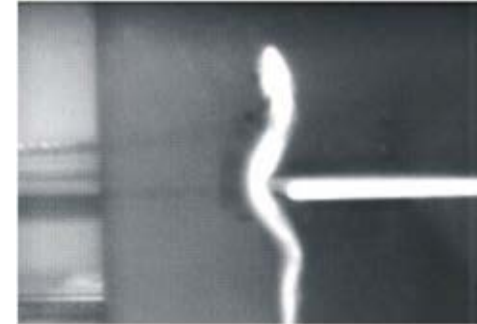

# Questions?

---

## Steve Amaral

**ALDEN** Research Laboratory, Inc.

30 Shrewsbury St., Holden, MA 01520-1843

Phone: (508) 829-6000 ext. 6415

[amaral@aldenlab.com](mailto:amaral@aldenlab.com)

[www.aldenlab.com](http://www.aldenlab.com)